



Voluntary Code of Practice on Broadband Speeds

Mystery shopping research

Research document

Publication date: 29 March 2010

Contents

Section		Page
1	Executive summary	2
2	Introduction	4
3	Results of mystery shopping research	8
4	ISPs' line checkers	12
5	Conclusions and next steps	16
Annex		Page
A	Glossary	18
B	Market research report	20

Executive Summary

Ofcom commissioned mystery shopping research to evaluate how Internet Service Providers (“ISPs”) are complying with the Voluntary Code of Practice on Broadband Speeds¹ (the “Code”) which was implemented in December 2008. ISPs who have signed-up to the Code commit to provide information to consumers before they enter into a contract about the maximum broadband speed they can expect on their line, and about the factors that will affect their actual speed.

The mystery shopping research shows that although more information on broadband speeds is now provided by ISPs following the introduction of the Code², information is still often not sufficient to allow consumers to have clear expectations about the broadband service they sign-up to. Of the total, 15% of the telephone mystery shoppers were not given an estimate of their access line speed (the maximum speed a consumer will be able to get)³, and 42% were only given one after prompting the sales agent near the end of the sales process. In addition, consumers are not always being given a consistent and accurate estimate of their access line speed. In some cases, ISPs gave an access line speed double that of another ISP for the same broadband line and technology. The majority of access line speed estimates given to mystery shoppers did not match (within +/-1Mbit/s) the speeds given by the BT Wholesale line checker⁴. Our analysis shows ISPs use a variety of ways to estimate access line speeds and present such estimates to consumers.

Without consistent and accurate calculation and presentation of access line speeds, the Code cannot deliver its intended benefits to consumers. We are working with ISPs to agree a common way of calculating and presenting estimates on access line speeds and will then seek to agree changes to the Code to reflect the agreed approach. We will also seek to ensure that consumers are given their access line speed estimate earlier in the sales process, before being asked for a firm commitment to sign-up.

Some consumers find their actual access line speed is significantly below the estimate given at the time of signing-up. Currently, the Code requires that ISPs should allow customers in this position to move to a lower-speed broadband package if one is available and their problems cannot be resolved. However, as more ISPs are starting to offer only single-speed packages, such a provision may become less useful to consumers. We will hence explore with ISPs whether to allow consumers to leave before the end of their contracted period if their access line speed is significantly below the estimate provided at point of sale, and this problem cannot be adequately resolved.

If appropriate changes to the Code cannot be agreed with ISPs, Ofcom may consider launching a regulatory review to ascertain whether it is necessary and appropriate to replace the Code with formal regulation.

We aim to achieve broad agreement with ISPs by summer 2010. Once the new Code is in place we will undertake further mystery shopping research in order to assess whether ISPs are complying with it.

¹ Available at <http://www.ofcom.org.uk/telecoms/ioi/copbb/copbb>.

² The Code was introduced in June 2008 and implemented in December 2008.

³ Included in this 15% are 3% of mystery shoppers who were told that the relevant line checker was temporarily unavailable and 3% who were told that the relevant ISP's database did not include information on their line.

⁴ Although some variation between ISPs can be expected as a result of network-specific factors, the differences we found were unlikely to be explained by this fact alone.

Section 1

Introduction

Why information on broadband speeds is important

Ofcom's primary duty under the Communications Act 2003 (the "Act") is to further the interests of UK citizens and consumers in carrying out our functions. In addition to securing the availability of a wide range of electronic communications services including broadband services, encouraging investment and innovation in relevant markets and the availability and use of high-speed data services, we must have regard to the interests of consumers in respect of price, quality and value for money. Our duties related to our consumer protection functions include the requirement to carry out research into consumers' experiences of using communications services, and to publish and take account of the results of our research.

Broadband speed is an important factor in determining a consumer's internet experience. While speed is not the only criterion on which consumers base their broadband purchasing decisions, a survey published by Ofcom in January 2009 suggested that broadband performance was just as important to consumers as price when deciding which ISP to choose⁵. Broadband is typically sold by its advertised 'up to' speed, but in the majority of cases consumers will not be able to achieve these "headline" speeds – Ofcom research found that consumers on 'up to' 8Mbit/s packages during April 2009 were on average able to achieve a maximum speed (what we call the "access line speeds") of 4.8 Mbit/s⁶.

This is chiefly because, for DSL broadband users, the maximum broadband speeds that a consumer will be able to achieve will depend on the length and quality of the copper wire connecting the user to the local exchange; the longer the distance and the poorer the quality of the line, the lower the access line speed. Figure 1 below details two DSL connections from the same exchange via the same ISP. The two customers have different line lengths and hence different access line speeds. The customers may find that the actual speeds they experience (what we call the "throughput speeds"⁷) are below their access line speeds as a result of other factors impacting on performance, such as congestion on their ISP's network and the number of people accessing a particular website. Note that for ISPs using cable technologies, the access line speed is not related to distance from the exchange, and it can therefore be expected to be the same as the headline speed of the relevant broadband package.

⁵ "Provision of quality of service information" Research Document dated 30 January 2009; Figure 32, http://www.ofcom.org.uk/consult/condocs/qos08/provision_qos/qos.pdf

⁶ "UK broadband speeds 2009" Research Report dated 28 July 2009; Figure 4.4, http://www.ofcom.org.uk/research/telecoms/reports/broadband_speeds/broadband_speeds/broadband_speeds.pdf

⁷ Throughput speeds are the actual speeds delivered to a customer and are also commonly called download speeds

Figure 1: Illustrative example of how distance from exchange can affect speeds on DSL connections

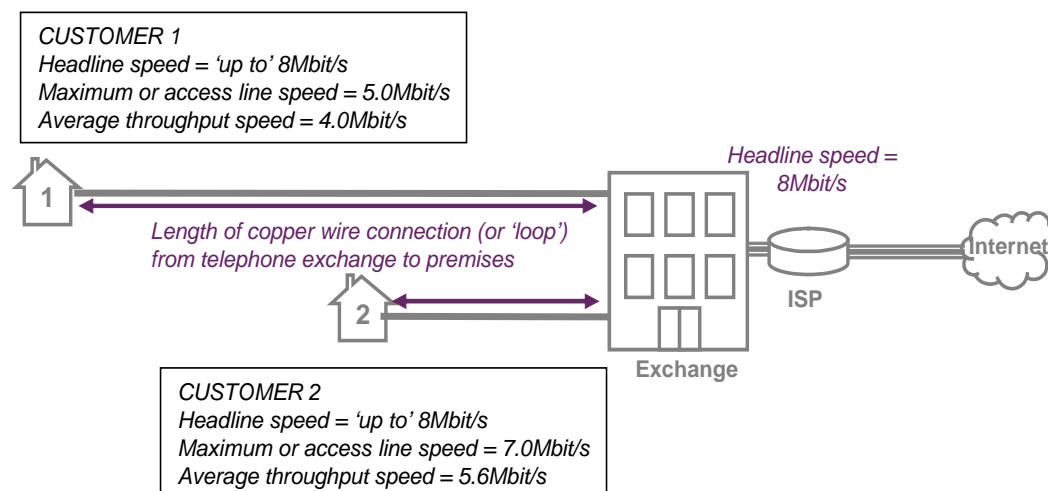

Ofcom's actions on broadband speeds

Ofcom has implemented a number of measures to help consumers understand more about broadband services, in particular what they should expect from their service in terms of performance and what they can do if they are unhappy with it. These measures include the following:

- In June 2008, Ofcom and fixed-line ISPs agreed a Voluntary Code of Practice on Broadband Speeds⁸ (the "Code"), which came into force on 5 December 2008. It requires ISPs who have signed-up to the Code to provide consumers with clear information on broadband services at point of sale, and in particular, on the access line speeds they can expect.
- In December 2008, we published a consumer guide to broadband speeds which explains the Code and informs consumers about the steps they can take to improve their broadband performance⁹.
- In January 2009, we published an initial research report which detailed high-level findings from a survey into consumers' experiences of using broadband services and findings from an initial round of broadband speeds research conducted in 2008¹⁰.
- In July 2009, we published a report on consumers' experience of broadband speeds, including the results of how different broadband providers and packages performed in terms of speed and other measures¹¹. We also published a new consumer guide to buying broadband services which is designed to better inform consumers about the factors they might wish to take into account when purchasing a broadband service¹².

⁸ Available at <http://www.ofcom.org.uk/telecoms/ioi/copbb/copbb>

⁹ <http://www.ofcom.org.uk/advice/guides/bbspeeds.pdf>

¹⁰ "UK broadband speeds 2008" Research Document dated 8 January 2009, http://www.ofcom.org.uk/research/telecoms/reports/bbspeed_jan09/bbspeed_jan09.pdf

¹¹ See footnote 5 above.

¹² <http://www.ofcom.org.uk/files/2009/07/bbchoice.pdf>

The Voluntary Code of Practice

The Code came into effect on 5 December 2008. Over 50 ISPs have signed the Code (a full list of signatories is available on the Ofcom website¹³). The Code requires, among other things, that ISPs:

- provide customers with an accurate estimate of their access line speed at the point of sale, whether it is in the shop, over the internet or on the phone;
- resolve technical issues to improve speed and offer customers the choice to move onto a lower speed package if available when estimates given are inaccurate;
- ensure all sales and promotion staff have a proper understanding of the products they are selling so they can explain to their customers the meaning of the access line speed estimates provided at the point of sale;
- highlight that the access line speed is only an estimate and explain that the actual throughput speed may be lower than the access line speed estimate; and
- provide customers with information on usage limits and alert customers when they have breached them.

The box below sets out the principles of the Code in more detail¹⁴.

The 7th Principle of the Code sets out Ofcom's commitment to monitor ISPs signatories' compliance with the Code through a number of methods, including mystery shopping. To date, we have conducted two mystery shopping exercises¹⁵ aimed at assessing the extent to which ISPs are complying with the Code. Further details, with a focus on the most recent research conducted in October/November 2009 and the key results of that research, are set out in the following section.

The eight principles of the Code

1. Training

ISPs agree to provide full training on how to implement the Code to people selling their broadband services. This includes not just their own people, but any agents or others such as shop staff.

2. Information where broadband is sold

Some ISPs use technology that means customers may not be able to get the maximum advertised speed. If so, these ISPs should:

- give customers an estimate of the maximum speed they can get;
- provide a 'line checker' on their website that estimates the maximum speed a customer can expect, and make sure this figure is clearly shown;
- not accept an order until a customer has been told their estimated speed; and
- give customers speed information in writing, or in a 'My account' section on their website or remind the customer to write the estimate down.

¹³ <http://www.ofcom.org.uk/telecoms/ioi/copbb/list/>

¹⁴ Also published on our website at <http://www.ofcom.org.uk/telecoms/ioi/copbb/consumerguide>

¹⁵ A preliminary mystery shopping exercise was conducted in May 2009 on our behalf by Continental Research in part to ensure we had a robust methodology to be able to test compliance with the Code effectively.

Every ISP must:

- explain clearly and simply how other technical factors may slow down the speed that users get; and
- avoid abusing the trust of vulnerable customers who may not understand what they're being told.

3. Up-to-date, accurate information

ISPs must do what they can to ensure that what they display on their line checkers is up-to-date and accurate. Ofcom will work together with the industry to help make sure that this is the case.

4. Dealing with speed problems

When ISPs use technology that means that customers may not get the maximum advertised speed, they should:

- have trustworthy systems to find the cause of speed problems when customers report them, and log any faults;
- give help and advice if customers can do something themselves to improve the situation; and
- offer an alternative package (if they have one), without any penalties, if the actual speed is a lot lower than their original estimate.

Every ISP must:

- have trustworthy systems to find the cause of a speed problem; and
- take steps to fix any issue that is down to them.

5. Giving information on websites

Many ISPs have a 'fair use' policy which may mean you can only use your service within certain limits. Others may also take steps to manage the highs and lows of 'traffic' on their networks. If they do, the Code says that they should explain their rules clearly on their website, in an obvious place (such as in 'Frequently Asked Questions'). They should where possible, help customers to measure usage, and email you details of any penalties for going over your limit.

6. Making things happen

ISPs should adopt the principles in the Code, in full, within six months of signing up.

7. Complying with the Code

The Code also sets out Ofcom's intention to monitor compliance with the Code by carrying out mystery shopping.

8. Customers and the Code

ISPs are also required to inform customers that they have signed-up to the Code, and publish the details on their website.

Section 2

Results of the mystery shopping research

Purpose of the mystery shopping research

In July 2009 we commissioned mystery shopping research to ascertain the extent to which ISPs who have signed-up to the Code were complying with it. This research was carried out by research agency Synovate over a one-month period in October/November 2009. One of the objectives of the research was to understand what proportion of consumers are being given information on the access line speed for their line during the broadband sales process. The report produced by Synovate is attached in the Annex, but we set out a summary of the key findings and our observations on these in this Section.

How the mystery shopping research was conducted

The mystery shoppers recruited by Synovate phoned and visited websites of ISPs who had signed-up to the Code and asked to purchase the ISP's broadband service. The shoppers then monitored whether ISPs were meeting the requirements under the Code. They noted whether or not they were given an access line speed, and if so, what speed they were given. If mystery shoppers were asked for bank details or a MAC¹⁶ by the sales agent, or they judged the call to be reaching a conclusion, they prompted the sales agent for access line speed information by making a specific enquiry about the speeds they would be able to receive. A quantitative mystery shopping approach was used, covering both telephone and website sales routes, and shoppers were provided with telephone sales numbers and website URLs for the relevant ISPs. Over 1,200 telephone and website shops were conducted across a range of ISPs between 30 October and 30 November 2009, across England, Scotland and Wales¹⁷.

Full details of the research methodology, including the questionnaire completed by the mystery shoppers, can be found in Annexes B and C of the research report prepared by Synovate which is attached in the Annex to this report.

Key results of the mystery shopping research

Overall, the exercise has revealed that while ISPs have made efforts to implement the procedures necessary to comply with the Code, compliance with the most important aspects of the Code could be improved further. Notably, consumers are not always being given an accurate, consistent estimate of their access line speed at the point of sale.

The key results of the mystery shopping research are set out below.

¹⁶ Migration Authorisation Code or "MAC" is a unique code which identifies a particular line and enables customers to switch ISPs smoothly and with minimal disruption.

¹⁷ Northern Ireland was not included because Synovate was not able to recruit a sufficient, representative sample of mystery shoppers in a time frame consistent with the mystery shops in England, Scotland and Wales. In future mystery shopping research we will aim to include concurrent mystery shops in Northern Ireland.

1. Most mystery shoppers received an access line speed estimate but many had to prompt the sales agent for it.

We found that the majority of shoppers (85%) were provided with an access line speed estimate during telephone shops¹⁸. But 42% of the mystery shoppers, i.e. half of those who were provided with an access line speed, had to prompt the sales agent for an access line speed at the point when they were asked for their bank details or a MAC, or they thought that the call was coming to an end, before the estimate was given to them.

The Code currently requires ISPs to provide the access line speed “within the sales process”, i.e. before completion of the process. Although asking for a MAC or bank details does not constitute completion of the sales process, Ofcom’s view is that consumers would be better informed if they were given the relevant information on access line speeds before being asked for these details - if provided, these details would indicate a strong commitment to purchase despite the fact that access line speed information had not yet been provided. Providing access line speed information early in the sales process would, however, ensure that consumers have the opportunity to make a properly informed choice since they would have information on access line speed information before making any strong commitment to signing-up. We will hence be seeking to ensure that ISPs give information on access line speeds early in the sales process by amending the Code to this effect.

2. Many of those who did not get an access line speed were told it was because line checkers were temporarily unavailable or could not recognise their line.

In total, 15% of mystery shoppers failed to get an access line speed estimate during telephone shops but included in this figure are 6% of shoppers who were told that it was because line checkers could not provide a speed estimate¹⁹. In 3% of total shops, ISPs explained that this was because of a temporary unavailability of the line checker²⁰. In a further 3% of telephone shops, ISPs were unable to give an estimate for the line in question since that line was not accessible in the relevant database. On further investigation, we found that this was because many ISPs do not have information on lines which use full local loop unbundling (“LLU”). The relevant data could not therefore be queried using the consumer’s telephone number; instead ISPs would have had to make a more complicated and less accurate query based on the customer’s postcode. However, as many ISPs were not able to do this with their current systems, they did not ask the customer for postcode details. We are therefore undertaking further work to address this issue (see further Section 3).

3. The access line speed estimates provided by different ISPs varied considerably and must have therefore often been inaccurate.

We were interested to ascertain if, and to what extent, there is any variation in ISPs’ estimates of access line speeds for a particular line. The mystery shoppers therefore used the same set of phone numbers when speaking to the different ISPs. The results show that the estimates provided for the same line varied considerably between different ISPs. In some cases, ISPs gave an access line speed double that of another ISP for the same broadband line and technology. As an indication of the variability, we found that fewer than half (43%) of access line speed estimates provided²¹ were within 1Mbit/s of the estimate

¹⁸ Figure 2a: Market research report

¹⁹ Figure 3: Market research report

²⁰ Line checkers estimate the access line speed for a particular customer using the line length, attenuation, capacitance or other metric (or a combination thereof).

²¹ Figure 12: Market research report

provided for the same line by the BT Wholesale line checker.²² On further investigation, we found that the reason for this is because ISPs currently use different methods to calculate estimates.

In practice, therefore, customers are likely to receive different estimates of access line speeds from different ISPs²³. We believe that this raises a significant issue, as it is a prerequisite for the effective operation of the Code, and for properly informing consumers, for ISPs to have a consistent approach in estimating and presenting access line speeds. We therefore intend to work with ISPs to achieve this (see further Section 3).

4. Access line speed estimates were often given in the form of a wide range.

In 10% of cases, ISPs provided the access line speed estimate in the form of a wide range (such as 10 to 20 Mbit/s) to telephone shoppers rather than a single number (such as 11 Mbit/s)²⁴. The Code currently requires that estimates are provided in the form of a single number. This is because a wide range may set the wrong expectations for consumers, e.g. a consumer given a wide range of 10 to 20 Mbit/s may expect a speed closer to 20 Mbit/s even though most customers will receive a speed closer to 10Mbit/s²⁵ - customers could in fact receive half the speed they expected. Furthermore, if an ISP charges more for its higher-speed packages, then a customer given a wide range for their access line speed may choose a higher-speed package (and hence pay more) in the expectation that they will receive that higher speed, even though they will not be able to. On the other hand, ISPs have told us that they sometimes provide a range because they believe that the line checkers used to estimate speeds are not necessarily accurate, and hence customers are given a more realistic expectation of their speed by being given a range rather than a single point estimate which is likely to be wrong. We will consider this further as we conduct further work into how consumers can be given more consistent and accurate access line speed information (discussed in section 3).

5. In 1 in 5 cases, line checkers on ISPs' websites did not give mystery shoppers an estimate of access line speeds.

Under the Code, ISPs are required to have available line checkers on their websites which provide an estimate of the customer's access line speed. Surprisingly, however, we found that in around one in five cases (21%) our mystery shoppers were not provided with an estimate of the access line speed through ISPs' website line checkers even though the shoppers were able to obtain an estimated access line speed from the BT Wholesale line checker²⁶. We are exploring in more detail with ISPs why this is the case and how it can be resolved.

6. There were often differences in the access line speed estimates provided to mystery shoppers by an ISP's website and by its telephone sales agent.

As well as conducting telephone shopping, the mystery shoppers also tested the ISPs' websites. In terms of consistency, the estimates of access line speeds provided by an ISP to

²² While the BT Wholesale line checker is not necessarily more accurate than an ISP's own line checker, we consider that it provides a common benchmark to assess the variation in ISP's estimates.

²³ There is likely to be some degree of variation between ISPs on account of other factors (such as the practice of providing lplates or equivalent devices as standard which may increase speeds for customers of specific ISPs) but such factors alone would not account for the much wider variations noted in this research.

²⁴ Figure 3: Market research report

²⁵ As a result of the inverse relationship between distance from exchange and achievable speeds

²⁶ Figure 4: Market research report

the shoppers over the web and the phone should be the same. The research found however that in 31% of cases there was a difference of more than 1Mbit/s between the estimates provided by those different sales channels, which suggests inconsistency in approach²⁷. In 18% of telephone shops, the estimate given was 1Mbit/s or greater than the estimate given for the same line on the ISP's website; in 13% of telephone shops, the estimate given for the same line was 1Mbit/s or more below that on the ISP's website.

7. In the majority of cases it was not made clear to mystery shoppers that the access line speed provided was only an estimate.

We believe that it is important for customers to understand that access line speeds provided by ISPs are only estimates, and that, in practice, the actual access line speed may vary from the estimate provided. However, the research found that only 40% of telephone mystery shoppers were informed that the access line speed was an estimate²⁸.

8. Most telephone mystery shoppers were not told that actual speeds were likely to be below access line speeds.

Having reviewed the ISPs' websites, Synovate concluded that information on the factors which affect actual speeds (such as fair usage policies, traffic management, etc.) is generally being provided on ISPs' websites²⁹ (although other factors, such as constraints on ISPs' network capacity, are often not mentioned). In addition, the assessment was that in many cases, the information provided could be more prominent, clear and concise. However, in the telephone shops, only 26% of shoppers were informed that the actual speed experienced was likely to be below the access line speed estimate provided³⁰ and only 31% were given information about the factors which affect actual speeds³¹. We will consider further, therefore, how we can ensure that consumers are given the information on the relevant factors which affect broadband speeds through all sales channels.

²⁷ Figure 5: Market research report

²⁸ Figure 6: Market research report

²⁹ Figure 16: Market research report

³⁰ Figure 8: Market research report

³¹ Figure 9: Market research report

Section 3

ISPs' line checkers

Consistency and accuracy of speed estimates

As discussed in Section 2, the mystery shopping research found considerable variation between ISPs' estimated access line speeds for the same location. And in some cases, there was also variation between estimates given by an ISP's website and by the ISP's sales agents over the phone for the same line. This indicates that the different methods or line checkers used by DSL broadband ISPs³² to provide estimates of access line speeds result in consumers being provided with inconsistent and inevitably inaccurate access line speeds across different ISPs. This is of concern because in our view one of the most important aspects of the Code is that ISPs provide consumers with a consistent and accurate estimate of their access line speed. The mystery shopping exercise involved testing over a hundred different telephone lines for each ISP, but an example showing the access line speed estimates provided by four different ISPs³³ for one particular line is shown in Figure 2.

Figure 2: Access line speed estimates provided by different ISPs' line checkers on their websites for one particular line

ISP	Estimate of access line speed
ISP A	9Mbit/s
ISP B	10-20Mbit/s
ISP C	8.5Mbit/s
ISP D	16Mbit/s

Source: Ofcom

ISPs need not provide exactly the same estimate for a given line, since there are factors under the control of an individual ISP which could allow it to provide better performance on a given line than its competitors, e.g. by ensuring the user's modem is well-matched with their exchange equipment, or by assisting the customer in optimising their in-home installation. But it is unlikely that the wide differences shown in Figure 2 would be justified these factors alone – hence, one or more of the estimates provided is likely to be inaccurate.

Why estimates of access line speeds vary by ISP

We have done some work to assess why this issue exists, in particular by looking at the methods that some of the larger ISPs use to provide access line speeds. We understand

³² As set out earlier in Section 2, the parts of the Code relating to the provision of information on access line speeds are not relevant to ISPs using cable where the access line speed is expected to be the same as the headline speed.

³³ One telephone line in north London was tested on four different ISPs' websites on 18 March 2010, and the access line speed provided for their respective ADSL2+ broadband services is shown in Figure 2.

that most ISPs derive the access line speed by using an estimate (provided by Openreach³⁴) of the length of a customer's line and by referring to information they hold about the access line speeds of their existing customers. If there were a simple straight-line relationship between line length and access line speeds, similar to that illustrated in Figure 3, it would be relatively easy for all ISPs to give a consistent and accurate estimate of access line speeds. Unfortunately, however, this is not the case.

Figure 3: A hypothetical straight line relationship between access line speeds and line lengths

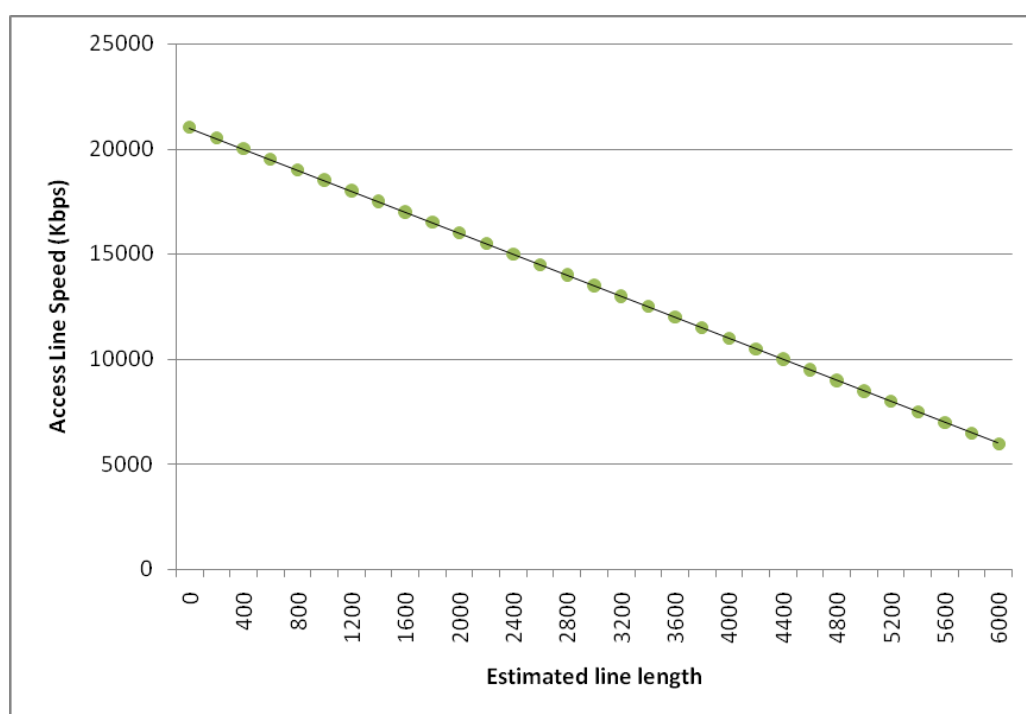

Source: Ofcom

Rather than being a straight-line inverse relationship between line length and access line speeds, there is a complex relationship. As discussed in Section 1, access line speeds depend on a range of different factors in addition to line length, including line quality and customer-specific factors such as internal wiring and the modem used. Hence, for any given line length, there is a wide range of access line speeds which could be achieved. This means that, far from being a straight-line inverse relationship, the relationship between line length and access line speeds is more akin to that shown in Figure 4. That figure is only for illustrative purposes, but it shows that for a line length of 1km, the access line speed for 90% of customers will be 6.5Mbit/s or above. But the range is quite broad, and this means that 80% of customers have an access line speed of between 6.5Mbit/s and 16.5Mbit/s, with 10% below the lower bound and 10% above the upper bound.

³⁴ Openreach is the BT Group business that operates the telephony local access network used by providers of ADSL based broadband in the UK (other than Hull). Openreach maintains a database of technical data associated with each active line, including estimates of the line length.

Figure 4: Illustrative example of the actual relationship between access line speeds and line lengths

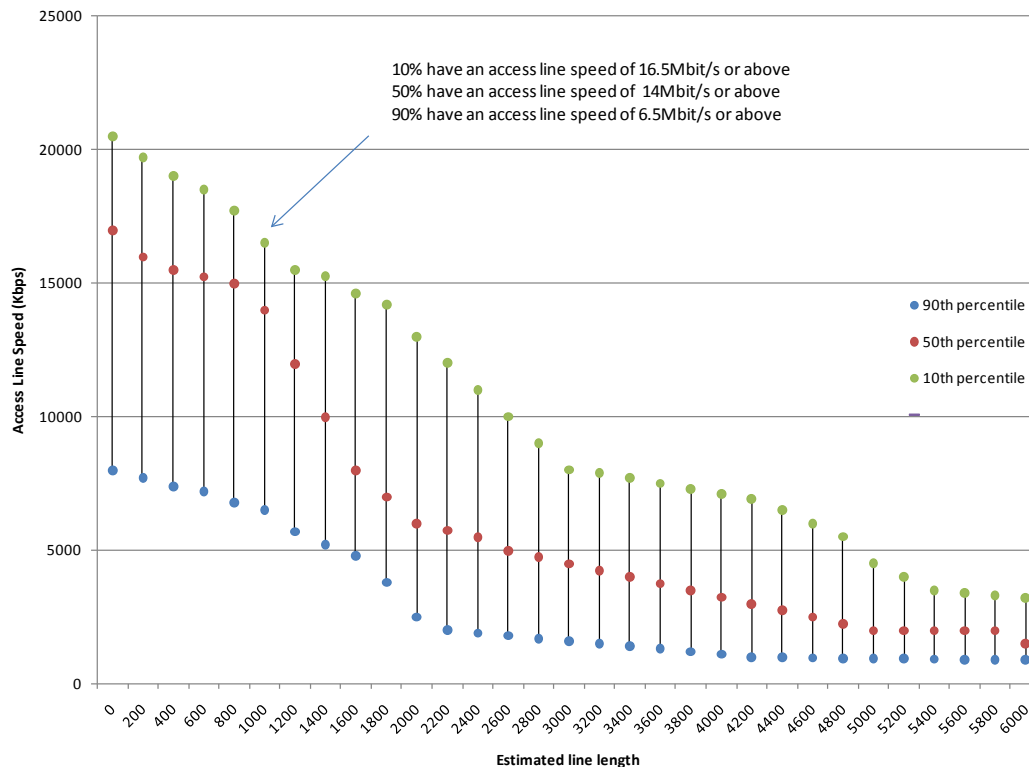

Source: Ofcom

It can be seen therefore that ISPs could use a number of different points within the possible distribution range as the estimated access line speed – and indeed that is precisely what they do. On further investigation we have found that different ISPs use different points within this range, including:

- The median speed achieved by a sample of existing customers with similar line length.
- The mean speed achieved by a sample of existing customers with similar line length.
- The 90th percentile speed achieved by a sample of existing customers with similar line length (i.e. the speed achieved by 90% of customers).

Furthermore, we have found that some ISPs do not use line length to calculate access line speed. Other methods currently used by the ISPs we asked include estimates based on the following:

- An estimate based on line capacitance³⁵.
- An estimate based on line attenuation³⁶.

Provision of consistent and accurate information

When the Code was originally drafted, it did not include any provisions to detail what methodology should be used by ISPs to generate speed estimates; ISPs were free to use

³⁵ The property of an element of an electrical circuit that permits it to store charge.

³⁶ The electrical loss of the line, which takes into account not only line length but also the type of metal used and wire gauge of the line.

the methodology that they considered most appropriate in order to comply with the Code. Hence ISPs have to make a choice about what method they use to calculate access line speeds and what point in the range of possible access line speeds they use as the estimate. Since they have adopted different methods, consumers are given different access line speeds from different ISPs – as the mystery shopping results show. Hence, Ofcom considers that consumers would benefit from the introduction of a more uniform practice across the industry that would reduce the risk of inaccuracy and inconsistency.

Adoption of a more consistent approach should reduce the variability in estimates between ISPs and therefore help consumers to make more informed choices. Ofcom therefore intends to undertake further work and analysis to improve access line speed estimates, before seeking agreement from ISPs on an improved methodology, and changing the Code accordingly.

Section 4

Conclusions and next steps

The mystery shopping research has allowed us to understand further whether consumers are being given adequate information on broadband speeds at point of sale, following the introduction of the Code. It is clear that although the Code has helped to give consumers better information, there remain a number of areas where, in our view, consumers are not being given the information they need to make informed choices.

We have discussed the results of the mystery shopping research with ISPs. They have told us that there may be a number of reasons which explain the results, e.g. training of new call centre staff and changes to their websites. They have also said that they are implementing measures such as improving their training materials to improve compliance with the Code, which we welcome. Nevertheless, we regard it as necessary to take action in a number of areas to ensure that the Code is implemented in a way that allows benefits to consumers to be fully realised. The actions we propose should help to resolve the problems identified in Section 2, and can be categorised under the following headings:

- Improving ISPs' line checkers
- Giving access line speed information early in the sales process
- Providing information on the factors that affect actual speeds
- Ensuring customers' speed-related problems are handled effectively
- Agreeing subsequent changes to the Code

Improving ISPs' line checkers

A number of the results of our mystery shopping research and related work have indicated that improving the line checkers used by ISPs should be a priority for Ofcom's future work in the area of broadband speeds:

- Our finding that ISPs are using different means of calculating and presenting access line speeds which is leading consumers to receive widely different access line speed estimates from different ISPs for the same line.
- The results from our mystery shopping which show that ISPs often give different estimates for the same line on their website and through their telephones sales channel.
- Results which show that access line speed estimates are often given in the form of a wide range, and which may therefore lead consumers to make inappropriate purchasing decisions.
- The finding that consumers with fully unbundled lines are sometimes not able to receive access line speed estimates from ISPs.

We consider that consistent and accurate calculation and presentation of access line speed information is a pre-requisite if the Code is to deliver its intended benefits to consumers. Hence, Ofcom's immediate priority is to ensure that ISPs take the necessary steps to ensure that they adopt a more consistent approach to providing access line speed estimates. By improving line checkers we should also be able to ensure that consumers are not given a wide range of access line speed estimates which could cause them to have unrealistic expectations about their service.

We are therefore working to identify a ‘best practice’ methodology to generate access line speed estimates. We are currently working with a number of ISPs to collect and analyse data that they hold on their own respective customer bases. Once we have identified a preferred approach, we will be working with industry to see how quickly this methodology can be adopted by ISPs and introduced into their systems. If ISPs agree to co-operate, we anticipate that this process could be concluded within a few months. In parallel, we will discuss possible solutions with ISPs and Openreach for the problem of consumers with fully unbundled lines who are unable to get access line speed information from some ISPs.

We envisage that the approach which is agreed with ISPs in this regard will be implemented through changes in the Code.

Giving access line speed information early in the sales process

Another way in which we will seek to amend the Code is to require ISPs to commit to giving the access line speed before asking for a MAC or bank details – as discussed in Section 2, many consumers are currently asked for this information before being given an access line speed. Currently the Code states that the speed has to be given ‘within the sales process’, i.e. before completion of the sales process. Although asking for a MAC or bank details does not necessarily constitute completion of the sales process, it may be difficult for customers to withdraw from the sales process after giving such details. Hence it is important that customers are given information on access line speeds before being asked for a MAC or bank details, and we will aim to agree with ISPs a change in the Code to this effect.

Providing information on the factors that affect actual speeds

We will also seek to find ways of ensuring that consumers are given information on the factors which affect actual broadband speeds (such as network capacity, congestion on the wider internet, and traffic management policies), as well as ensuring that consumers are informed that actual throughput speeds may be below access line speeds. As discussed in Section 2, we found that such information was usually presented on ISPs’ websites but was not usually given by telephone sales agents. Such information is likely to be useful, however, to consumers because it will ensure they have the right expectations about their broadband service. We have been told by ISPs that it can be difficult for agents to impart this information easily and effectively through telephone sales channels, and we will therefore discuss with ISPs the best way of ensuring that consumers are given this important information.

Ensuring consumers’ speed-related problems are handled effectively

The Code currently requires ISPs to take measures to manage situations where customers receive access line speeds which are significantly lower than the estimate provided at point of sale. Where these problems cannot be resolved, the Code requires ISPs to offer customers an alternative, lower speed broadband package where the ISP offers such a package. The Code states that consumers should not incur any penalty in order to migrate onto a different broadband package under these circumstances.

Since the introduction of the Code, ISPs have been increasingly moving towards offering only a single-speed package, e.g. offering new customers an ‘up to’ 20 Mbit/s with actual speeds dependent on the access line speed available on the customer’s particular line.

We intend to explore with ISPs therefore whether the existing provision which allows customers to move to lower speed packages continues to be appropriate, or whether it would be appropriate to replace it. A replacement provision could, for example, allow customers to leave their contracts without penalty where they receive an access line speed significantly below the estimate provided when they originally signed-up³⁷ and the problem cannot be adequately resolved.

We will discuss with ISPs whether such a provision is practicable, proportionate and appropriate, which includes considering further issues such as the potential benefits to consumers; the potential costs involved; issues of practical implementation; and the relationship between such provision and existing general consumer law.

Agreeing subsequent changes to the Code

Considering the issues above, if appropriate subsequent changes to the Code are agreed with ISPs, we will amend the Code accordingly. If ISPs do not agree to such changes, then we may consider further whether it is appropriate to launch a regulatory review to consider the case for formal regulation in this area, for example through a new General Condition³⁸. Such a review is likely to take more than a year to complete, during which time the existing Code would continue to remain operational.

Timing and next steps

We are keen to progress with introducing appropriate amendments to the Code and will therefore aim to achieve broad agreement with ISPs (who wish to become signatories of a revised Code) by the Summer. Once the new Code is in place, we will undertake further mystery shopping research in order to assess whether ISPs are complying with it.

³⁷ Some ISPs already have a similar provision, offering a 30-day period during which customers can leave without penalty if they are unhappy with their service.

³⁸ General Conditions of Entitlement, see http://www.ofcom.org.uk/telecoms/ioi/g_a_regime/gce/

Annex A

Glossary

Access line speed The maximum broadband download speed that a line is capable of supporting. See also Maximum line speed.

ADSL Asymmetric Digital Subscriber Line. A digital technology that allows the use of a standard telephone line to provide high speed data communications. Allows higher speeds in one direction (towards the customer) than the other.

ADSL1 The first generation of ADSL, capable of data speeds of up to 8Mbit/s towards the customer and up to 640kbit/s from the customer.

ADSL2/ADSL2+ Improved versions of ADSL, offering high speeds, especially on shorter telephone lines. In the case of ADSL2+, up to 24Mbit/s can be delivered towards the customer.

Broadband A service or connection generally defined as being 'always on' and providing a bandwidth greater than narrowband.

Broadband speed The speed at which data are transmitted over a broadband connection, usually measured in megabits per second (Mbit/s), and usually used to refer to the download speed

Download speed Also downlink or downstream speed. Rate of data transmission from a network operator's access node to a customer, typically measured in Megabits per second (Mbit/s).

DSL Digital Subscriber Line. A family of technologies generally referred to as DSL, or xDSL, capable of transforming ordinary phone lines (also known as 'twisted copper pairs') into high-speed digital lines, capable of supporting advanced services such as fast internet access and video-on-demand. ADSL, HDSL (high data rate digital subscriber line) and VDSL (very high data rate digital subscriber line) are all variants of xDSL).

Exchange The local telephone exchange is the building where all consumers' copper telephone lines are connected to enable telephone calls to be switched, and where network equipment is installed which enables consumers' data traffic to be routed via an operator's core network to its destination.

Headline speed The speed at which a broadband service is marketed, usually expressed as 'up to'. Typically, the headline speed represents the theoretical maximum download data speed that can be achieved by any consumer on this package. A number of factors, such as the quality and length of the physical line from the exchange to the customer, mean that a customer may never experience this headline speed in practice.

ISP Internet Service Provider. A company that provides access to the internet.

Kbit/s Kilobits per second. A unit measuring the bit-rate in multiples of 1,024 bits per second. 1,000Kbit/s is the same as 1Mbit/s.

LLU (local loop unbundling) LLU is the process whereby incumbent operators (in the UK this means BT and Kingston Communications) make their local network (the lines that run from customer's premises to the telephone exchange) available to other communications

providers. The process requires the competitor to deploy its own equipment in the incumbent's local exchange and to establish a backhaul connection between this equipment and its core network.

Local loop The access network connection between the customer's premises and the local PSTN exchange, usually a loop comprising two copper wires.

Maximum line speed The highest download speed that a broadband connection is capable of delivering. Also known as the access line speed. As it is a characteristic of DSL broadband that speeds degrade with distance from exchange, the maximum line speed varies, and, for ADSL1 connections, only those users who have a line length of less than 1km typically achieve maximum speeds of close to a headline speed of 8Mbit/s.

Mbit/s Megabits per second. A unit measuring the bit-rate. 1Mbit/s is the equivalent of 1,000Kbit/s.

Throughput speed The actual speeds delivered to consumers over a broadband connection, usually measured in Megabits per second, and generally referring to the download speed.